



# The Pairwise Comparison Method

Colin Watson

6 December 2023

Australian Council *for* Educational Research

# Learning progression scale with MPL benchmarks

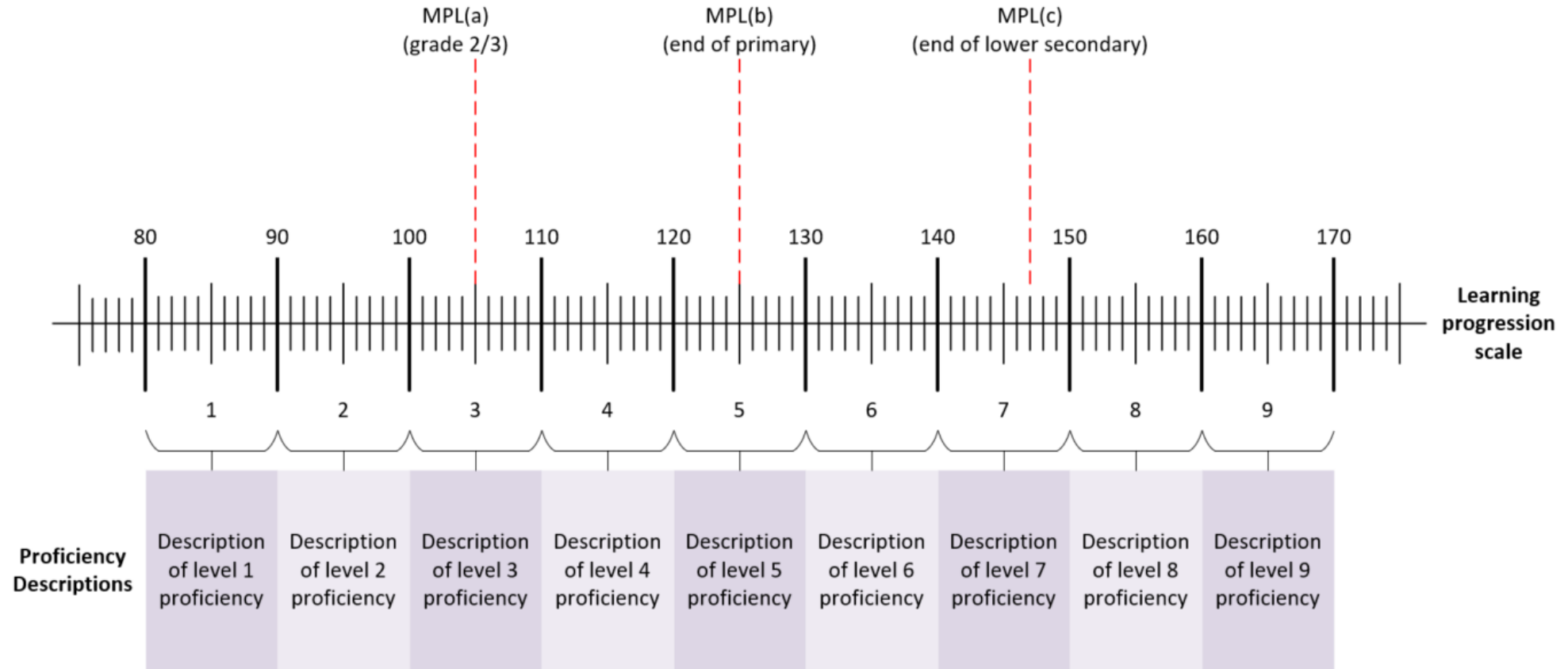

# The Pairwise Comparison Method – steps

**Step 1:** a self-assessment to determine whether the assessment instrument is of sufficient validity to be suitable for SDG 4.1.1 reporting.

**Step 2:** a pairwise comparisons exercise to place items from the assessment instrument onto the Learning Progression Scale (LPS).

**Step 3:** statistical, common items, linking to place MPL benchmarks on the assessment instrument reporting scale.

# Step 1 – assessment appropriateness

UNESCO Institute for Statistics has determined three criteria for assessments to be suitable for SDG 4.1.1 reporting:

- Alignment with the Global Proficiency Framework
- Appropriate assessment development process
- Appropriate sampling methodology
- Standardisation of assessment administration
- Sufficient reliability of assessment outcomes

## Step 2 – the Pairwise Comparison Method

Two sets of items:

- One set that are already mapped to the learning progression scale
- One set from A.N.Other assessment that we wish to map onto the scale

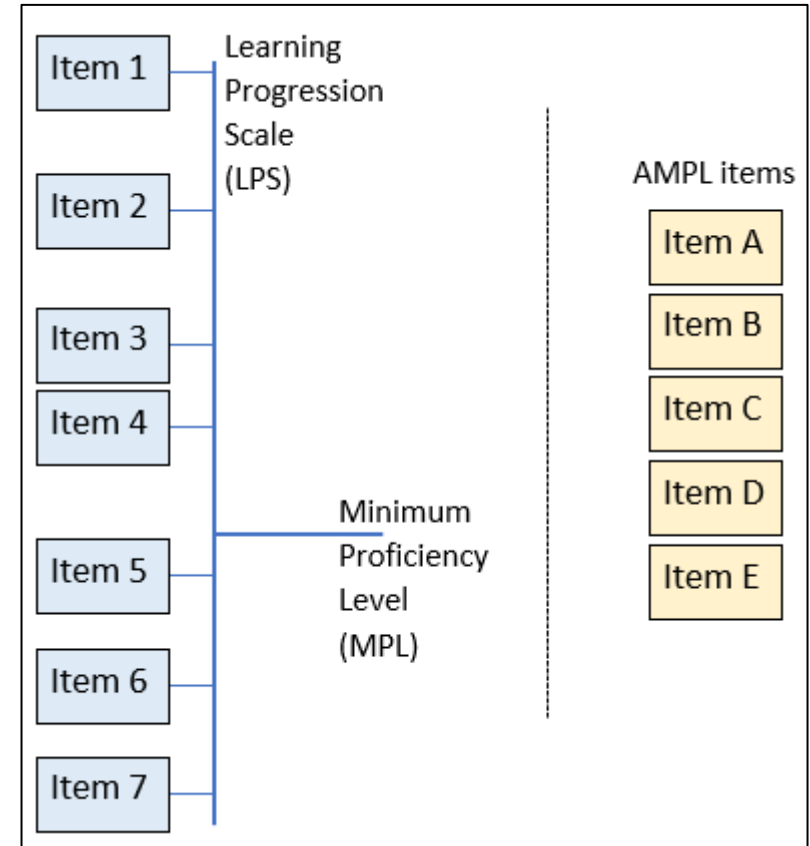

# Step 2 – the Pairwise Comparison Method

- Consider pairs of items at a time
- Which of the pair of items is more difficult?

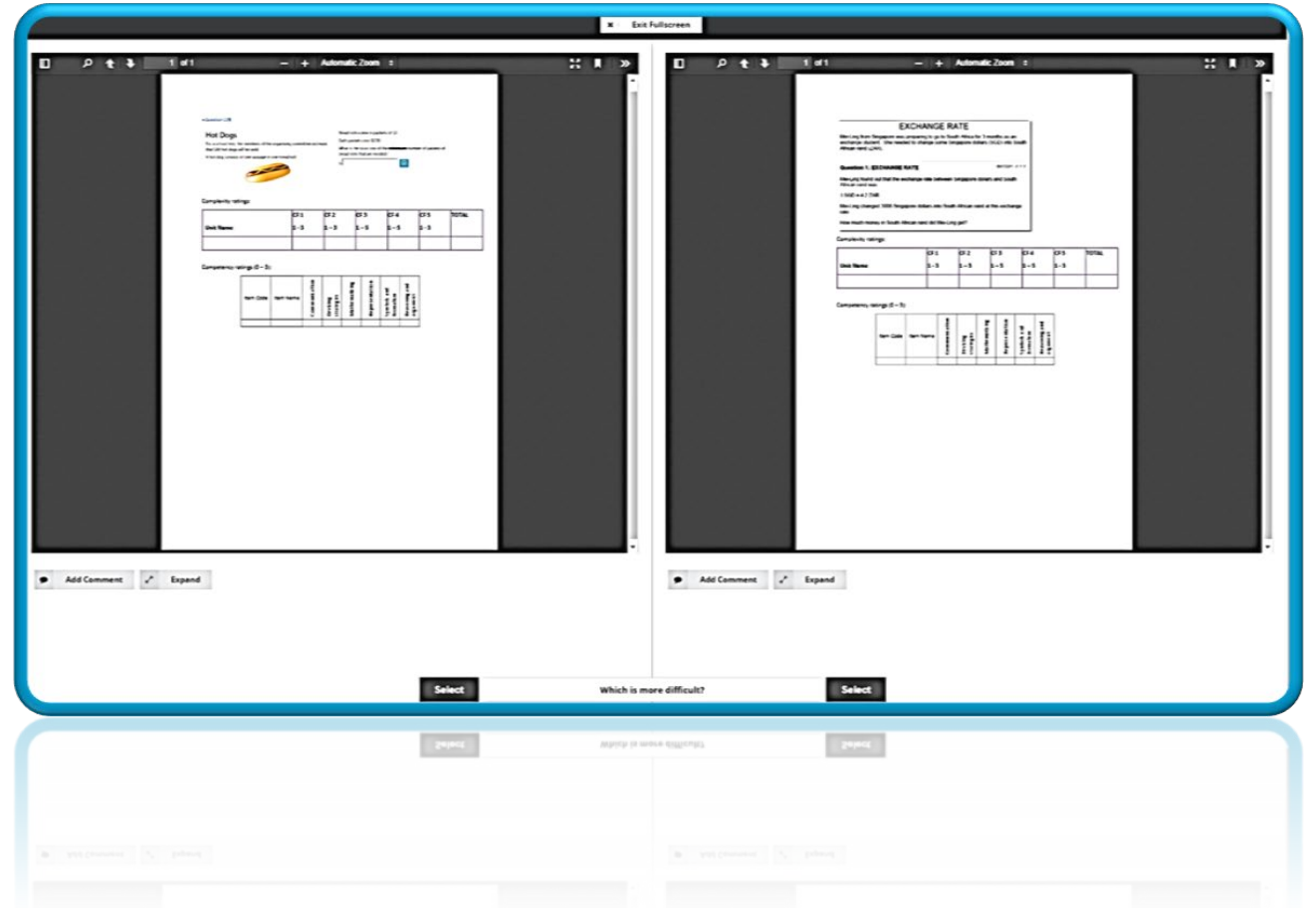
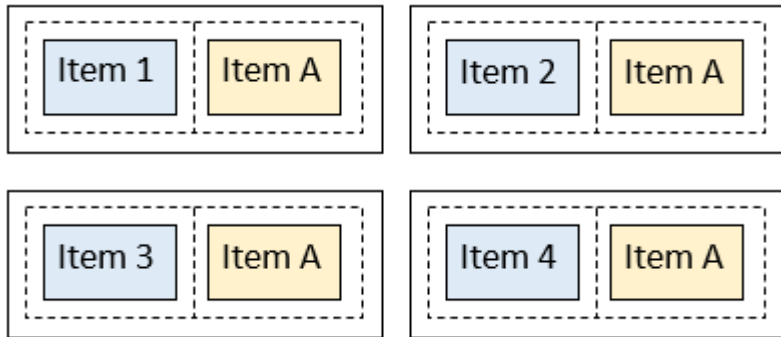

## Step 3 – statistical linking to set MPL benchmarks

- Once all the comparisons are made, we can map the new items on the same scale as the old items
- We can also determine the cut score on A.N.Other assessment that equates to the minimum proficiency level

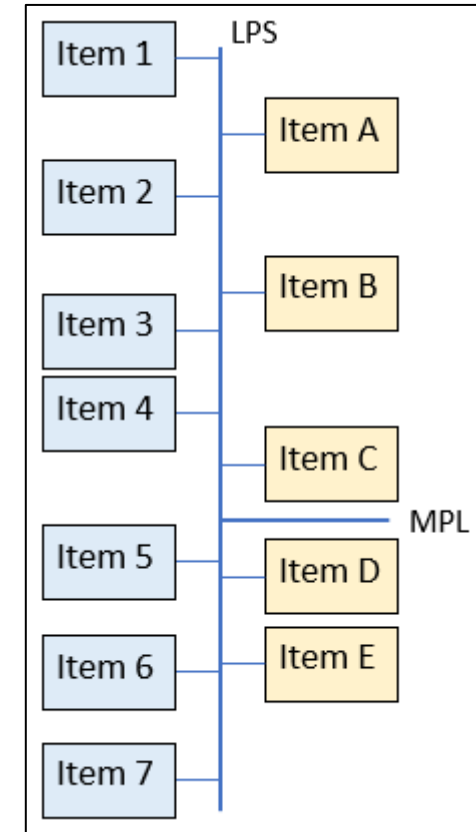

# PCM advantages for setting global benchmarks

**Cheaper and faster** than other statistical linking methods.

**Panellist training is simple** and does not require extensive preparation.

**Can be implemented consistently** using an online application.

**New assessment items can be added to LPS** to build an invaluable resource to support capacity development and strengthen the LPS and SDG 4.1.1 reporting.



# PCM Toolkit

ACER has developed a toolkit to support the implementation of the PCM.

This will be published after GAML, as it is dependent on the eligibility criteria being discussed tomorrow.

The toolkit will help any organisation implement the method, though they will need to be familiar with the pairwise comparison analysis.

The toolkit will be updated following feedback from those who have used it before finalisation.

# PCM Toolkit - contents

The toolkit contains the following sections:

- Introduction to the method
- Self-assessment criteria (to follow)
- Preparing for the workshop
- Implementing the workshop
- Self-assessment of the outcomes
- Documentation to support the implementation of the workshop (activity planners, invitation letters, etc.)
- Workshop facilitation slides
- Analysis requirements
- Report template

ACER

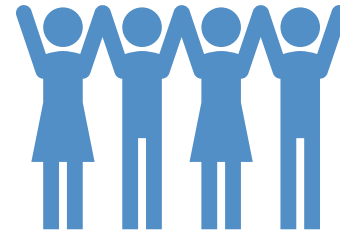

Thank you

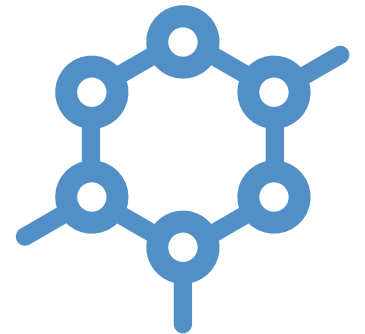

# References

- Pairwise Comparison Method: Concept note – Global Alliance for Measuring Learning (GAML) paper, November 2022. [https://tcg.uis.unesco.org/wp-content/uploads/sites/4/2022/11/WG\\_GAML\\_12\\_Pairwise-Comparison-Method\\_ACER.pdf](https://tcg.uis.unesco.org/wp-content/uploads/sites/4/2022/11/WG_GAML_12_Pairwise-Comparison-Method_ACER.pdf)